

# MODUFLEX LOADING CHUTE N300

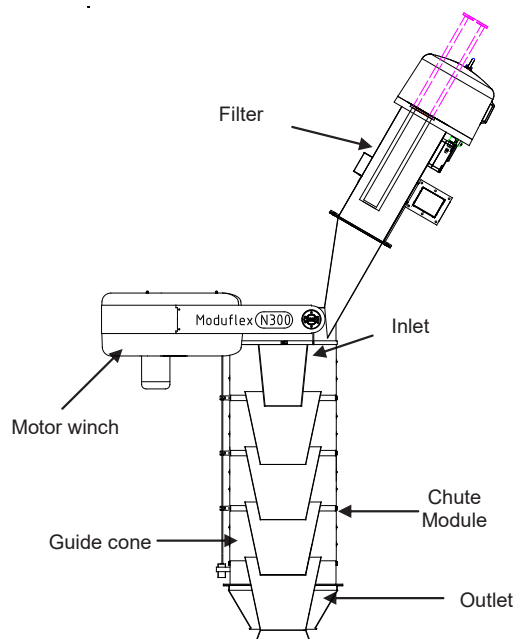

## GENERAL

Brand	Cimbria
Designation	Moduflex Loading Chute
Model	N300
Use	Designed for dust-free out-loading of dry bulk material.



## Technical Information - N300

Inlet	Conical inlet tube in 4 mm steel. Fitting Ø300 PN10 flange (2576B). Mounted with 12 off M20 bolts. Side-mounted filter module with built-in cartridge filter, pressure tank, magnetic valves etc. 9 off filter cartridges, totals 9 m <sup>2</sup> , alternatively 14 m <sup>2</sup> or 18 m <sup>2</sup> . Fan with 0,75 kW motor.
Chute modules	Type Y - Standard: Yellow. PVC/Polyester. Ø600mm/H=300mm. Temperature -35°C - +70°C Type M - Food Grade: Light Grey. PVC/Polyester. Ø600mm/H=300mm. Temperature -30°C - +70°C Type W - Special: Misc. PVC/Polyester. Ø600mm/H=300mm. Temperature -35°C - +70°C Type B - Heavy Duty: Black. Synthetic rubber. Ø600mm/H=300mm. Temperature -40°C - +130°C Type G - Extreme Temperature: Grey. Teflon/Fiber glass. Ø600mm/H=300mm. Temperature -35°C - +260°C Type R - High Temperature: Red. Polyester and fiber/silicone rubber. Ø600/H=300. Temp. -40°C - +150°C (peak +220°C) Type Z - Low temperature: Green. PVC/PU. Ø600mm/H=300mm. Temperature -60°C - +70°C Connection ring in stainless steel Aisi 304, c/w 3 off wire guides in nylon.
Guide cones	Type O - Support ring. Steel, H=30mm Type U - Ultramid. Polyamide 6.6. H150mm, pt=6mm. Type J - Steel Standard. Steel, H150mm, pt=2mm. Type L - Steel Overlapping. Steel, H405mm, pt=2mm.
Outlet	Type T - Tank Outlet with steel cone for loading in tanker truck. Type F - Flat Outlet with dust skirt for loading in open truck. Type M - Multi Outlet with steel cone and dust skirt for loading in tanker truck and open truck.
Motor winch	Motor 0.55-2.2 kW, 1400 rpm. Gear box ratio 100:1. Tight and slack wire indication External 3-point wire hoist system with high precision ball bearings and 3 off winch discs vertically fitted. Hoist wires Ø5mm available in steel, stainless steel Aisi316 or Long Life steel quality. Self-lubricating wire rollers in Ertalite TX, alternatively steel/stainless steel with bronze bearing
General info	Max. loading capacity approx. 250 m <sup>3</sup> /hour. Compressed air supply, clean and dry for filter: Connection 5-6 bar. Filter cleaning air consumption 100-150 NL/min. Pressure air connection ½". Metal parts available in painted steel st. 37 or stainless steel Aisi 304. Other steel qualities on demand. Surface treatment St. 37: Iron phosphating, 80 micron coating RAL 9010 pure white. Surface treatment Aisi 304: Acid-washed without any further treatment Motor winch covers in ABS - RAL 6005 dark green. Cover on filter RAL 6005 Available with full approval and certificates for location in ATEX zone 21 and 22 (zone 20 inside the chute)

Accessories for Loading Chute N300, please see separate Data Sheet

# MODUFLEX LOADING CHUTE N300

N300									
	Outlet type TH			Outlet type FH			Outlet type MH		
Cone	Overlapping steel			Overlapping steel			Overlapping steel		
M	L1	L2	L3	L1	L2	L3	L1	L2	L3
1	948	691	257	1270	1013	257			
2	1255	741	514	1577	1063	514			
3	1562	791	771	1884	1113	771			
4	1869	841	1028	2191	1163	1028			
5	2176	891	1285	2498	1213	1285			
6	2483	941	1542	2805	1263	1542	2805	1263	1542
7	2790	991	1799	3112	1313	1799	3112	1313	1799
8	3097	1041	2056	3419	1363	2056	3419	1363	2056
9	3404	1091	2313	3726	1413	2313	3726	1413	2313
10	3711	1141	2570	4033	1463	2570	4033	1463	2570
11	4018	1191	2827	4340	1513	2827	4340	1513	2827
12	4325	1241	3084	4647	1563	3084	4647	1563	3084
13	4632	1291	3341	4954	1613	3341	4954	1613	3341
14	4939	1341	3598	5261	1663	3598	5261	1663	3598
15	5246	1391	3855	5568	1713	3855	5568	1713	3855
16	5553	1441	4112	5875	1763	4112	5875	1763	4112
17	5860	1491	4369	6182	1813	4369	6182	1813	4369
18	6167	1541	4626	6489	1863	4626	6489	1863	4626
19	6474	1591	4883	6796	1913	4883	6796	1913	4883
20	6781	1641	5140	7103	1963	5140	7103	1963	5140

N300 with Flexfill				
Cone	Steel/support ring			
M	LC	L1	L2	L3
3	1990	2294	1460	834
4	2297	2601	1510	1091
5	2604	2908	1560	1348
6	2911	3215	1610	1605
7	3218	3522	1660	1862
8	3525	3829	1710	2119
9	3832	4136	1760	2376
10	4139	4443	1810	2633

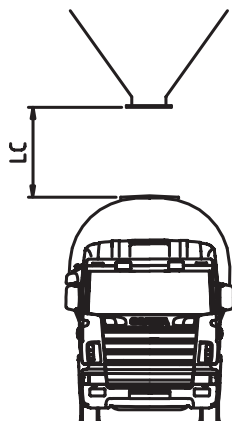

LC measure to be used when the loading chute is fitted with FlexClose or FlexFill.

N300 with FlexClose - no indicator				
Cone	Overlapping steel			
Indicator	None			
M	LC	L1	L2	L3
2	1186	1456	942	514
3	1493	1763	992	771
4	1800	2070	1042	1028
5	2107	2377	1092	1285
6	2414	2684	1142	1542
7	2721	2991	1192	1799
8	3028	3298	1242	2056
9	3335	3605	1292	2313
10	3642	3912	1342	2570

N300 with FlexClose and FlexSeal - no indicator				
Cone	Overlapping steel			
Indicator	None			
M	LC	L1	L2	L3
2	1186	1456	972	484
3	1493	1763	1022	741
4	1800	2070	1072	998
5	2107	2377	1122	1255
6	2414	2684	1172	1512
7	2721	2991	1222	1769
8	3028	3298	1272	2026
9	3335	3605	1322	2283
10	3642	3912	1372	2540

N300 with FlexClose with/without FlexSeal - with indicator							
Cone	Overlapping steel			Overlapping steel			
Indicator	Rotating/capacitive			Vibration rod			
M	LC	L1	L2	L3	L1	L2	L3
2	1186	1616	1102	514	1686	1172	514
3	1493	1923	1152	771	1993	1222	771
4	1800	2230	1202	1028	2300	1272	1028
5	2107	2537	1252	1285	2607	1322	1285
6	2414	2844	1302	1542	2914	1372	1542
7	2721	3151	1352	1799	3221	1422	1799
8	3028	3458	1402	2056	3528	1472	2056
9	3335	3765	1452	2313	3835	1522	2313
10	3642	4072	1502	2570	4142	1572	2570

