

Pre Cleaner DELTA 145



Cimbria DELTA Pre Cleaner 145 is specifically designed for pre cleaning of all cereals, maize, rice, peas, rape seed and similar material before drying or storage using a 13 m² screen area in conjunction with a sophisticated aspiration system.

The screen cleaner is equipped with feeding roller, one scalping screen, two rows of pre screens and two rows of sand sieves.

The screen cleaning effect of the 13 m² screen area is increased by Cimbria's highly effective pre- and after suction system, extracting light impurities from the material both at the machine inlet and outlet. The pre- and after suction waste, dust and lightweight trash is deposited in two separate expansion chambers and conveyed to the machine outlets by two discharge augers which are equipped with multifold air lock system to prevent ingress of air, i.e. false air.

The 1 m² scalping screen separates the coarse impurities. After that, the two rows of pre screens separate oversize material and the two rows of sand sieves separate undersize material and sand.

the screens are kept clean by a number of special rubber balls which bounce in between the screens dislodging any obstruction.

The ball boxes are designed so that it is not necessary to take out the boxes when changing the screens.

The sieves are manufactured in a standard size so that they fit all other types of DELTA screen cleaners and are available with various round or oblong perforations according to the material to be cleaned.

All the shutters and air valves are adjusted and controlled from the sacking off side of the machine using precise worm adjustment devices at an easy accessible operational height.

Like all other DELTA screen cleaners the base and the frame of type 145 is built in heavy gauge pressed steel of a very rigid construction. The screen boats are manufactured of selected insect and moisture resistant marine plywood.

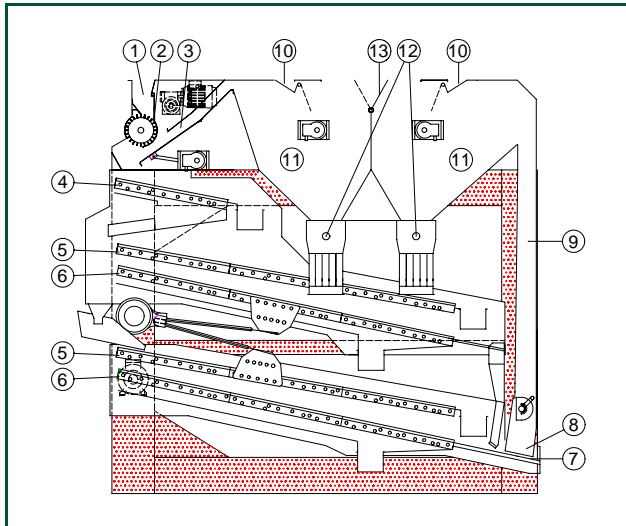

1. Inlet

The inlet is equipped with a feeding roller dispersing the material to be cleaned equally over the entire width of the machine. Stepless speed adjustment of the feed roller is achieved with a separate frequency controlled motor. In addition to this the feed roller is equipped with a 3-step sprocket wheel regulation. This enables the throughput to be adjusted very precisely to suit the particular material being cleaned. A buffer bin, supplemented with level control, is recommended.

1a. Alternative inlet

Optimal feed over the width of the machine is achieved by a shaker feeder with stepless adjustment via frequency regulating. Ensures an uniform feeding on the entire width of the machine also when cleaning difficult flowing products, i.e. grass seed, in addition the shaker feeder also prevent the product from flowing when the shaker feeder has stopped.

Max. capacity 50 t/h.

2. Spring loaded safety flap

3. Pre Suction System

The pre suction system removes dust and light weight trash before screening. The aspiration opening of the pre suction channel is adjustable thus achieving a variable air velocity.

4. Scalping Screen

The 1 m² scalping screen separates the most coarse impurities.

5. Pre screens

6. Sand Sieves

Each of the two screen boats comprises 2 rows of sieves. The upper screens in each of the two rows separate oversize material, while the two lower screens separate undersize material and sand. Total screen area is 12 m².

7. Outlet for Cleaned Product

8. Air Screen

Light weight particles are "air separated" at the screen which is positioned under the suction opening of the after suction channel. Air screens are delivered with two different types of wire mesh.

9. After Suction Channel

The light weight product separated at the air screen is conveyed through the after suction channel to the expansion chamber.

10. False Air Intake

Two false air flaps for controlling the air quantity in both the pre- and after suction system.

11. Expansion Chambers

12. Screw Conveyor

Two screw conveyors discharge the products separated in the expansion chambers to the sacking off points.

13. Air Divider Shutter (suction point)

Distribution of the air quantity for respectively pre- and after suction system.

CAPACITY GUIDE (max. 20% moisture content):

Wheat, Barley, Maize	60 t/h
Rice	30-35 t/h
The capacity may vary depending on the waste quantity and the moisture content of the raw material	

Overall Dimensions:

Height (without fan)	2895 mm
Length	3270 mm
Width (incl. motor)	2300 mm
Screen area	13 m ²

Motors:

Feed roller	1.1 kW
Alternative shaker feeder, max. capacity 50 t/h	0.75 kW
Screens	1.5 kW
Fan (optional/extra)	7.50 kW

Air volume:

Pre- and after suction	11000 m ³
------------------------	----------------------

Weight:

Freight volume	2310 kg
----------------	---------

Dynamic load (4.6-4.8 Hz)

Ph = +/- 1986 N	Pv = +/- 2188 N	(10 N = 1 kg)
-----------------	-----------------	---------------

For further information please ask for the Dimension Drawings, the Principle Diagram and the Operations and Instruction Guidance for screen cleaning machines.