

Data Sheet 115

Cimbria DELTA 115



Cimbria DELTA 115 has been developed for high quality fine cleaning of malting barley, seed grain, legumes, grass and garden seeds.

The machine's efficient screen system with its accurately matched stroke and frequency, is complemented by Cimbria's highly developed pre- and after suction system.

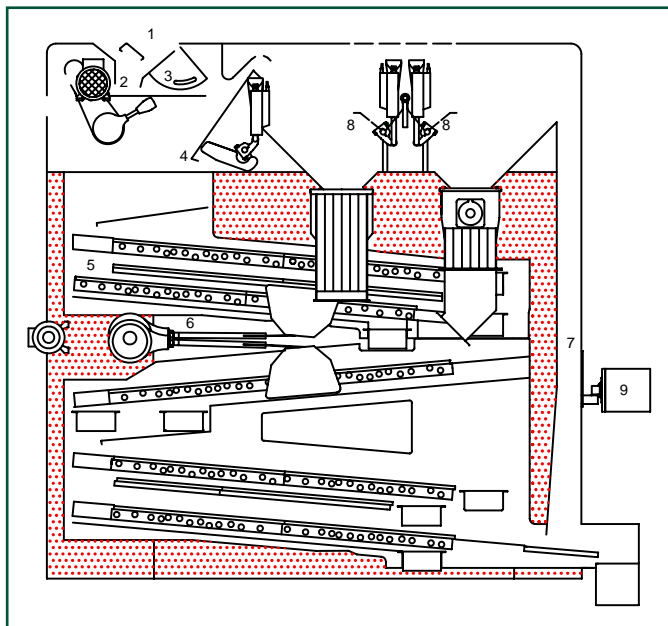

1. Inlet

Optimal feed over the width of the machine is achieved by a shaker feeder with stepless adjustment via frequency regulation.

2. Shaker feeder

Ensures an uniform feeding on the entire width of the machine also when cleaning difficult flowing products, i.e. grass seed, in addition the shaker feeder also prevent the product from flowing when the shaker feeder has stopped.

3. Adjustable feed gate

The feed gate will only be adjusted when the opening need to be bigger due to difficult flowing products, i.e. grass seed.

4. Pre-suction

With finely adjustable suction intake directly under the feed gate for effective removal of fine particles.

5. Screens

(L x W = 800 x 1250 mm) can be employed as sieves, sorters or graders, and are effectively kept clean by rubber balls in newly developed ball boxes. It is not necessary to take out the ball boxes when changing screens.

6. Eccentric drive system for screen boats

Supplied standard with fixed speed or alternative frequency regulation.

7. After suction

Light particles are sucked out of the product flow on the air screen and lead through the lifting air channel to the expansion chamber, from where they are extracted by screw conveyor.

8. False air intakes (2 pcs.)

For adjustment of air quantity in both the pre- and after suction systems.

9. Adjustment

Remote control of integral motor for shaker feeder, pre suction, after suction and air velocity. The adjustment of the above is placed in a small control box, which is placed on the cleaner.

Capacity based on 15% H ₂ O: 10% removal to EU Standard 90+8+2	
Wheat, Rye, Sorghum and Malted Barley	7.5 t/h
Oats, Maize, white Rice	6.0 t/h
Soya, Peas, Rape, Coffee	6.0 t/h
Paddy rice,	4.5 t/h
Sunflower, roasted Coffee	3.0-3.5 t/h
Rye grass, clover	1.3-1.6 t/h
Dimensions:	
Machine height (without ventilator)	2498 mm
Machine length	3086 mm
Machine breadth	1855 mm
Height, standard inlet hopper	532 mm
Screen area:	
	10.0 m ²
Square outlet pipes:	
(Adapter to round available)	
a) from screens	160 x 160 mm
b) from expansion chamber	240 x 240 mm
Motors: (standard)	
Screen	1.5 kW
Shaker feeder (integral)	0.75 kW
Top ventilator (optional)	5.5 kW
Air volume:	
Pre- and after suction	9800 m ³
Total weight of cleaner	
Without top ventilator	2075 kg
Freight volume	15 m ³
Dynamic loading at 4.6 - 4.8 Hz:	
PH= +/- 2515 N	PV= +/- 955 N
10 N = 1 kg	

Technical data can vary for certain of the above due to continued development, or a different machine composition.

This DELTA machine can, in a few minutes, be converted to different cleaning programmes, e.g.:

- Beans, lupine seed, maize
- Oats, wheat
- Malting barley
- Rye grass, Red fescue
- Rape, peas, lentils

Copyright © - The right to alterations is reserved