

Data Sheet 114

Cimbria DELTA 114

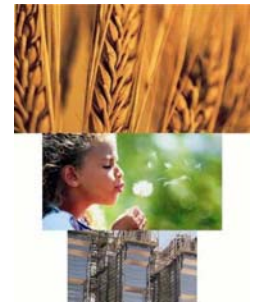

Cimbria DELTA 114 has been developed for high quality fine cleaning of malting barley, seed grain, legumes, grass and garden seeds.

The machine's efficient screen system with its accurately matched stroke and frequency, is complemented by Cimbria's highly developed pre- and after suction system.

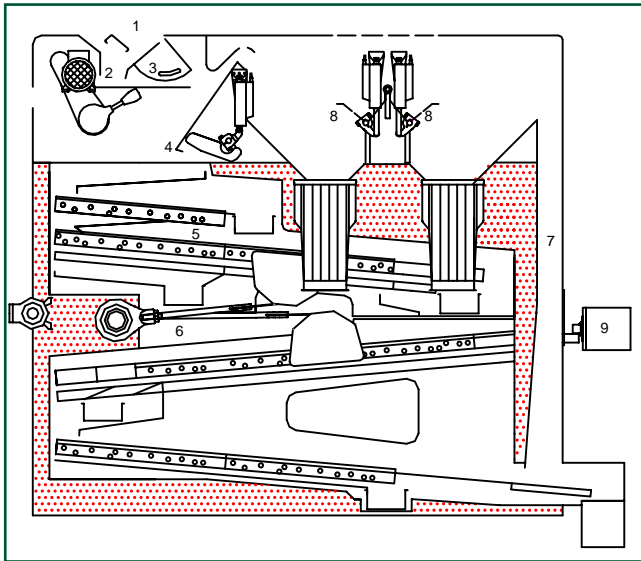

1. Inlet

Optimal feed over the width of the machine is achieved by a shaker feeder with stepless adjustment via frequency regulation.

2. Shaker feeder

Ensures an uniform feeding on the entire width of the machine also when cleaning difficult flowing products, i.e. grass seed, in addition the shaker feeder also prevent the product from flowing when the shaker feeder has stopped.

3. Adjustable feed gate

The feed gate will only be adjusted when the opening need to be bigger due to difficult flowing products, i.e. grass seed.

4. Pre-suction

With finely adjustable suction intake directly under the feed gate for effective removal of fine particles.

5. Screens

(L x W = 800 x 1250 mm) can be employed as sieves, sorters or graders, and are effectively kept clean by rubber balls in newly developed ball boxes. It is not necessary to take out the ball boxes when changing screens.

6. Eccentric drive system for screen boats

Supplied standard with fixed speed or alternative frequency regulation.

7. After suction

Light particles are sucked out of the product flow on the air screen and lead through the lifting air channel to the expansion chamber, from where it is extracted by screw conveyor.

8. False air intakes (2 pcs.)

For adjustment of air quantity in both the pre- and after suction systems.

9. Adjustment

Remote control of integral motor for shaker feeder, pre suction, after suction and air velocity. The adjustment of the above is placed in a small control box, which is placed on the cleaner.

Capacity based on 15% H₂O: 10% removal to EU Standard 90+8+2

Wheat, Rye, Sorghum and Malting Barley	5.0 t/h
Oats, Maize, white Rice	4.0 t/h
Soya, Peas, Rape, green Coffee	4.0 t/h
Paddy rice	3.0 t/h
Sunflower, roasted Coffee	2.0-2.5 t/h
Rye grass, clover and Beet seed	0.75-1.0 t/h

Dimensions:

Machine height (without ventilator)	2270 mm
Machine length	3068 mm
Machine breadth	1815 mm
Height, standard inlet hopper	532 mm

Screen area:

7.0 m²

Square outlet pipes:

(Adapter to round available)	
a) from screens	160 x 160 mm
b) from expansion chamber	200 x 200 mm

Motors: (standard)

Screen	1,5 kW
Shaker feeder with integral motor	0,75 kW
Top ventilator (optional)	5.5 kW

Air volume:

Pre- and after suction	8200 m ³
------------------------	---------------------

Total weight of cleaner

Without top ventilator	1970 kg
Freight volume	14 m ³
Dynamic loading at 4.6 - 4.8Hz:	
PH= +/- 123 N PV= +/- 1075 N 10 N = 1 kg	

Technical data can vary for certain of the above due to continued development, or a different machine composition.

This DELTA machine can, in a few minutes, be converted to different cleaning programmes, e.g.:

- Beans, lupine seed, maize
- Oats, wheat
- Malting barley
- Rye grass, Red fescue
- Rape, peas, lentils